

M2-Mitic-GL option VIS

Dispositifs d'acquisition et d'affichage
et de capture d'images et vidéos

Kadi Bouatouch

kadi.bouatouch@irisa.fr

http://www.irisa.fr/prive/kadi/Master_MITIC/

Plan

- Image acquisition systems (IAS)
 - Camera models
 - CMOS camera
 - CCD camera
 - Image reconstruction (recovery)
 - Parameters and tuning
- Display technology (DT) : LCD, Plasma, LED
- Photometry and colorimetry
- Sound acquisition systems (SAS)

IAS: camera models

- **Perspective projection**

- The origin of the camera frame R_c is the **centre of projection** C
- The axis x_c is oriented parallel to the scan-lines of the image plane and the axis y_c parallel to its columns.
- The intersection of the axis z_c with the image plane is the **principal point** u_0, v_0
- **Focal distance** $f = d(C, \pi)$

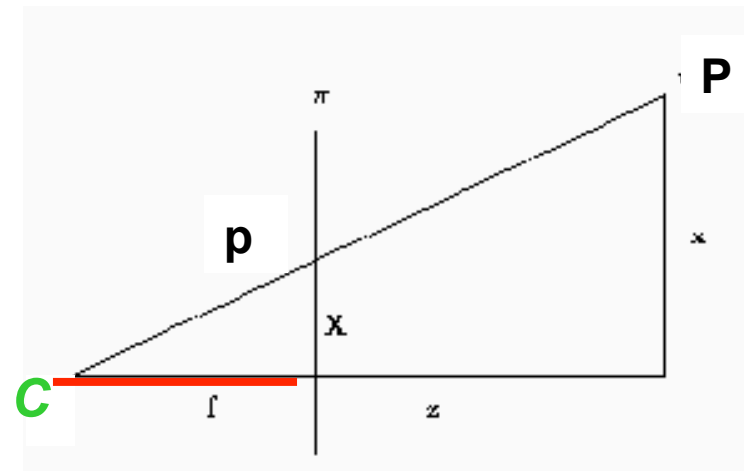
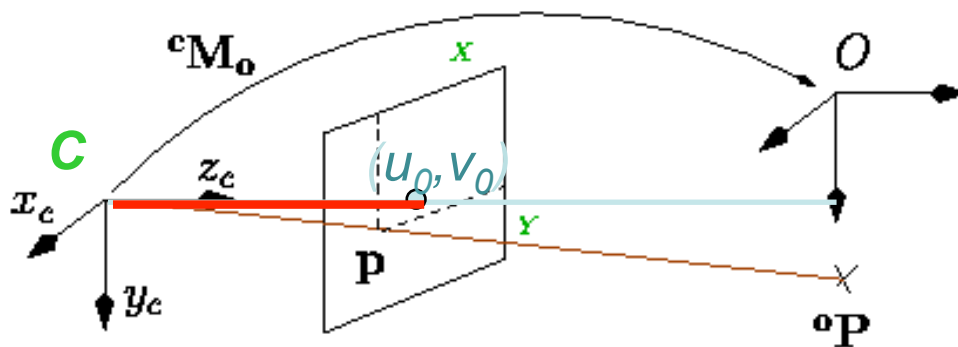

IAS : camera models

- **Perspective projection:** In R_c , the perspective projection of a point $P(X, Y, Z)$ onto the image plane is $p(x, y)$:

$$x = f X / Z , y = f Y / Z \quad \begin{cases} fX - Zx = 0 \\ fY - Zy = 0 \end{cases}$$

- All points belonging to the line CM project onto the same point p . It is then impossible to determine a single point P with only one camera.

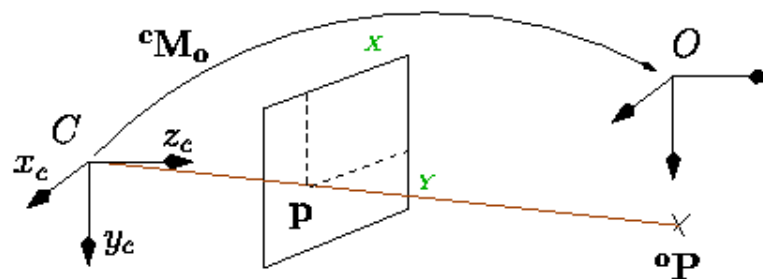

IAS : camera models

- **Radial distortion:** Let K be the radial distortion coefficient, then the position of point \mathbf{p} , really observed, in the image is

$$x_d = x + Kx(x^2 + y^2) , y_d = y + Ky(x^2 + y^2)$$

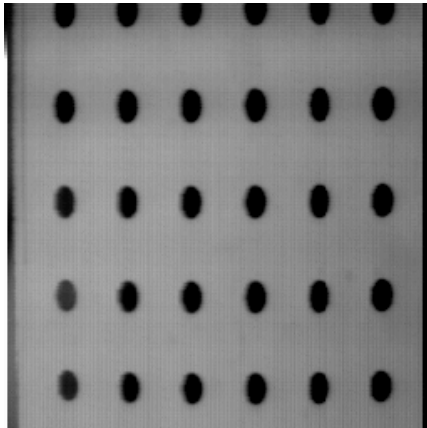

f=12mm

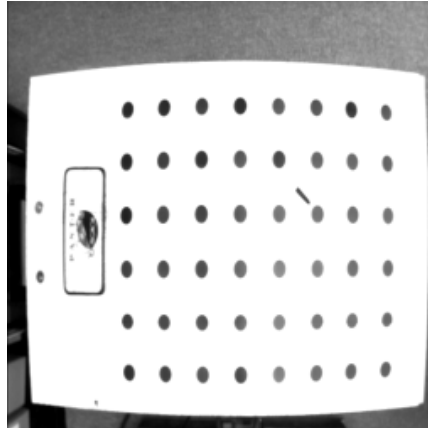

f=4.8mm



IAS : camera models

- **Sampling:** now let us express p_d (x_d, y_d) through its position p (u, v) in the sampled image (in pixels) :

$$u = u_0 + x_d / l_x , \quad v = v_0 + y_d / l_y$$

where l_x and l_y represent the pixel size

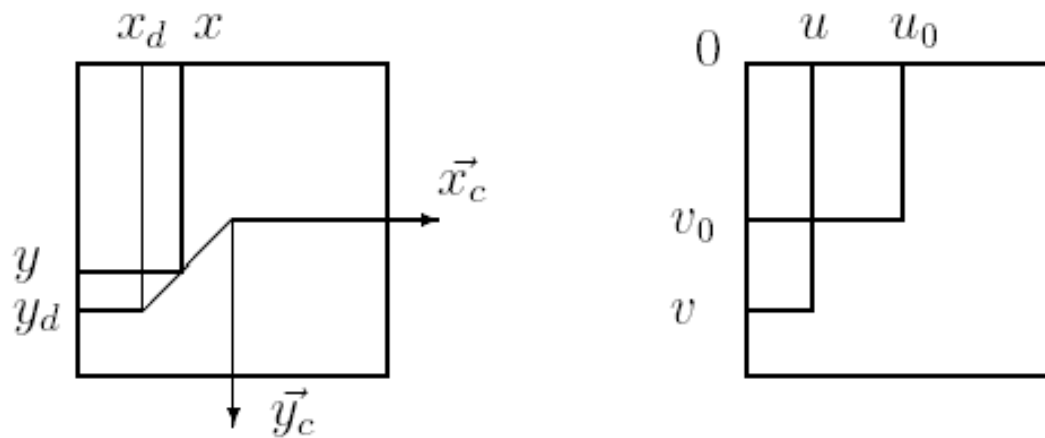

IAS : camera models

- **Complete model of the camera:**

$$\begin{cases} u = u_0 + p_x \frac{X}{Z} + K_d p_x \frac{X}{Z} \left(\frac{X^2}{Z^2} + \frac{Y^2}{Z^2} \right) \\ v = v_0 + p_y \frac{Y}{Z} + K_d p_y \frac{Y}{Z} \left(\frac{X^2}{Z^2} + \frac{Y^2}{Z^2} \right) \end{cases}$$

- Where

$$p_x = f/l_x, p_y = f/l_y \text{ and } K_d = K f^2.$$

- The parameters to be identified ξ , called intrinsic parameters, are:

$$\xi = (u_0, v_0, p_x, p_y, K_d)$$

IAS : camera models

- Complete model of the camera:
 - In case the radial distortion is negligible, we get a simple model:

$$\begin{cases} u = u_0 + p_x \frac{X}{Z} \\ v = v_0 + p_y \frac{Y}{Z} \end{cases}$$

IAS : camera

- Digital Still Cameras (**DSC**) : a derivative of the **camcorder** technology (video camera) modified to capture still images.
- Two factors contribute in differentiating the two systems:
 - The Human Visual System (HVS) characteristics
 - The quality of the analog cameras
- Motion reduces the HVS sensitivity to the high frequency contents (including artifacts) of a picture

IAS : camera

- Consequence: the system is intended for motion picture capture, the algorithms used can take advantage of that.
- The complete system benefits from the reduced sensitivity of the HVS: simpler algorithms translate into less hardware, lower power consumption and lower cost.
- On the other hand, the image processing algorithms required for DSC are very demanding as far as quality is concerned due to
 - The HVS characteristics for stills
 - And the quality already provided by analog still cameras

IAS : camera

- Initially, DSCs were strictly derived from Camcorders
- Consequently, the demand in quality for DSC greatly differentiated the 2 systems.
- Today, camcorders benefit from the advances made to enhance the quality provided by DSC.
- Example: progressive sensors with Bayer CFA developed for DSC now are used in digital Camcorder.

IAS : camera

- DSC working principle

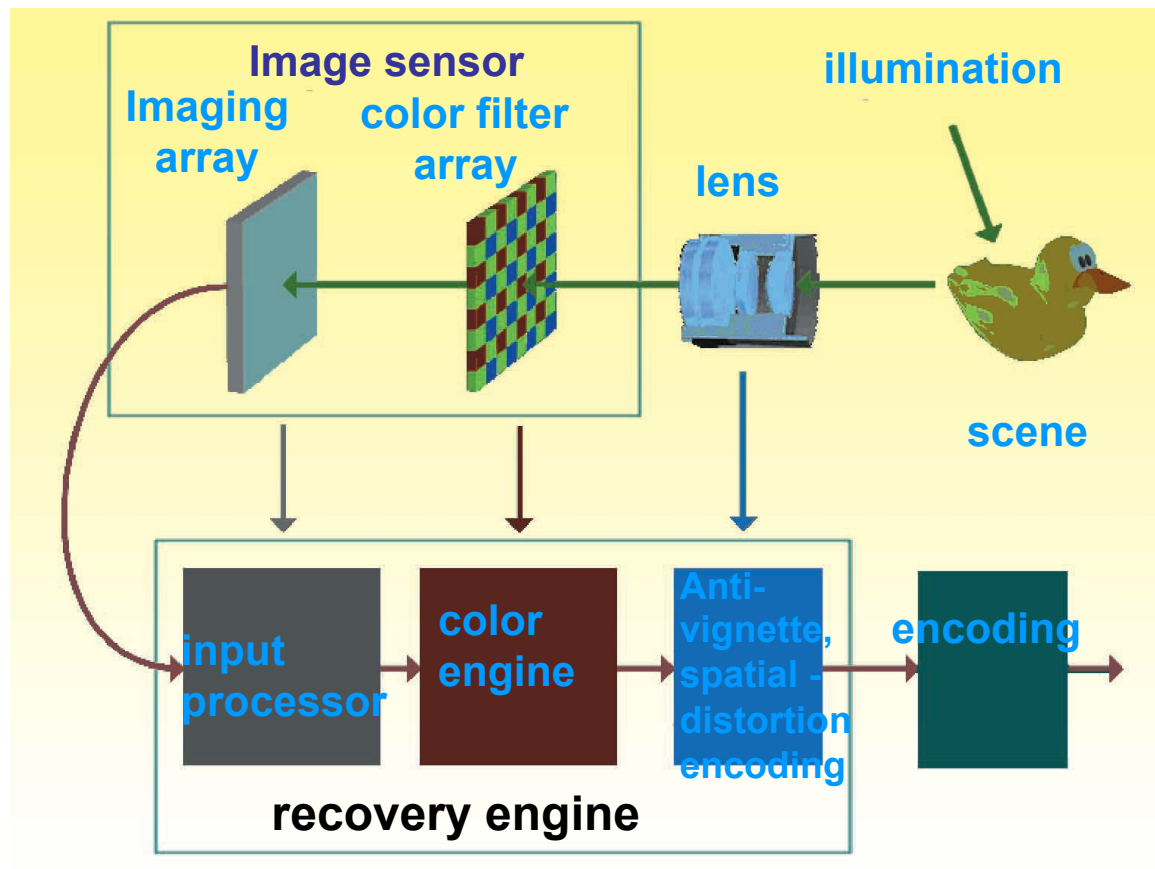

IAS : CMOS and CCD cameras

- Both CMOS and CCD chips sense light through similar mechanisms, by taking advantage of the **photoelectric** effect, which occurs when photons interact with crystallized silicon to promote electrons from the valence band into the conduction band.
- The term "CMOS" refers to the process by which the image sensor is manufactured and not to a specific imaging technology.

IAS : CMOS and CCD cameras

- Photo-sensor: electrons are collected in a **potential well** until the integration (illumination) period is finished, and either converted into a voltage (CMOS processors) or transferred to a metering register (CCD sensors).
- The measured voltage or charge (after conversion to a voltage) is then passed through an analog-to-digital converter, which forms a digital electronic representation of the scene imaged by the sensor.
- The resulting charge that accumulates in each pixel is linearly proportional to the number of incident photons.
- The photodiode, often referred to as a pixel, is the key element of a digital image sensor.

IAS : CMOS cameras

- Result : photodiode array

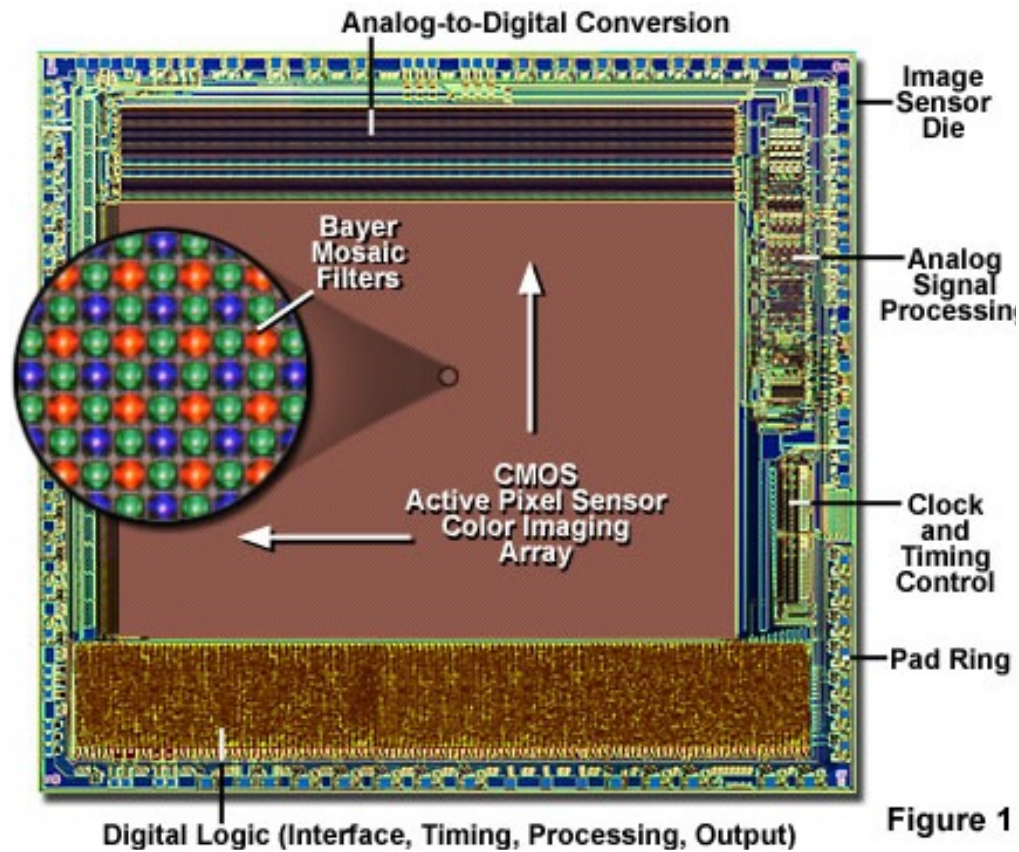

IAS : CMOS cameras

- CCD imager: photodiode array
- The most popular CMOS designs are built around **active pixel sensor (APS)** technology in which both the photodiode and readout amplifier are incorporated into each pixel.
- This enables the charge accumulated by the photodiode to be converted into an amplified voltage inside the pixel and then transferred in sequential rows and columns to the analog signal-processing portion of the chip.

IAS : CMOS cameras

- Each pixel (or imaging element) contains, in addition to a photodiode, a triad of transistors that converts accumulated electron charge to a measurable voltage, resets the photodiode, and transfers the voltage to a vertical column bus.
- The resulting array is an organized checkerboard of metallic readout busses that contain a photodiode and associated signal preparation circuitry at each intersection.
- The busses apply timing signals to the photodiodes and return readout information back to the analog decoding and processing circuitry housed away from the photodiode array.
- This design enables signals from each pixel in the array to be read with simple x,y addressing techniques, which is not possible with current CCD technology.

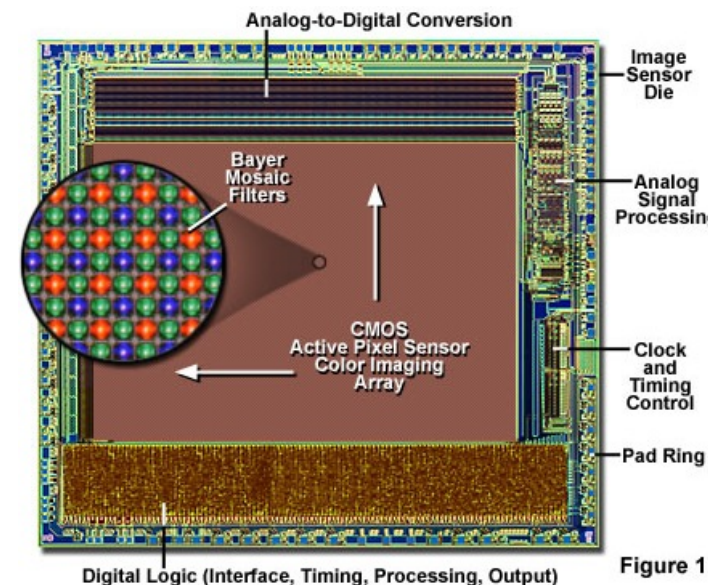

IAS : CMOS cameras

- A thin layer of red, green, and blue-dyed polymeric filters, each sized to fit over an individual photodiode.
- A sequential pattern of red, green, and blue filters that are arranged in a mosaic pattern named after Kodak engineer Bryce E. Bayer.
- This color filter array (a **Bayer** filter pattern) is designed to capture color information from broad bandwidth incident illumination arriving from an optical lens system. The filters are arranged in a quartet ordered in successive rows that alternate either red and green or blue and green filters.

IAS : CMOS cameras

- A photodiode array having pixel dimensions of 640 x 480 pixels contains a total of 307,200 pixels, which yields 76,800 Bayer quartets.

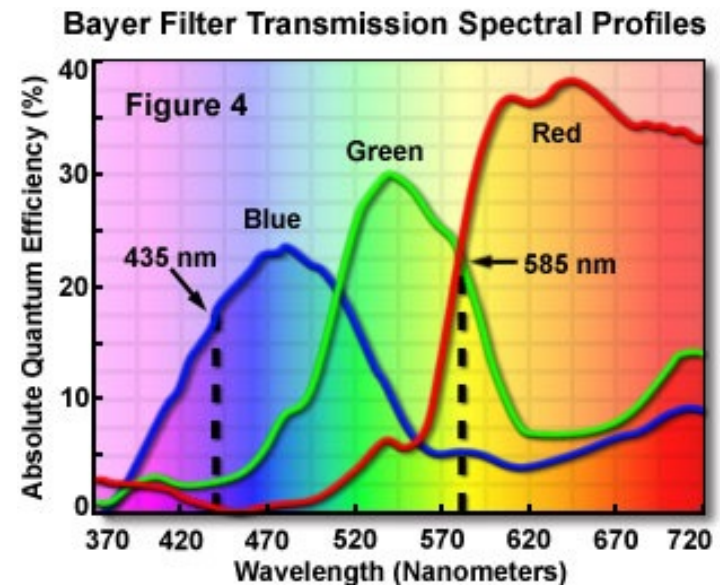
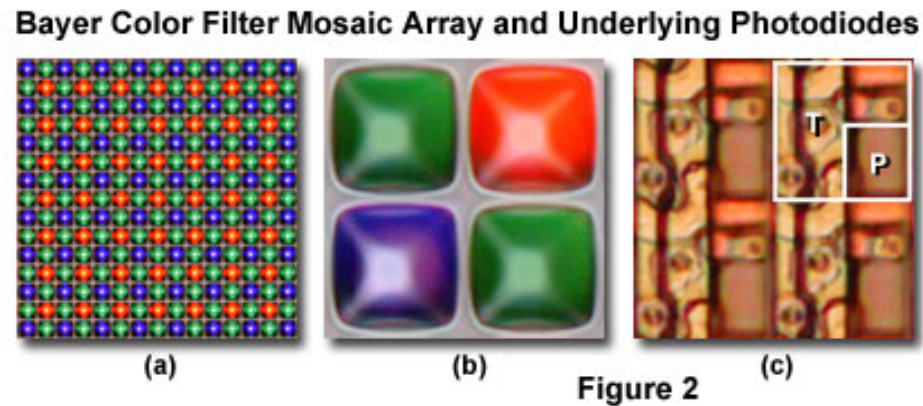

IAS : CCD cameras

- CCD photon detector: a thin silicon wafer divided into a geometrically regular array of thousands or millions of light-sensitive regions that capture and store image information in the form of localized **electrical charge** that varies with incident light intensity.
- The variable electronic signal associated with each picture element (pixel) of the detector is read out very rapidly as an intensity value for the corresponding image location.
- A CCD imager consists of a large number of light-sensing elements arranged in a two-dimensional array on a thin silicon substrate.

IAS : CCD cameras

- The fundamental light-sensing unit of the CCD is a metal oxide semiconductor (**MOS**) capacitor operated as a photodiode and storage device.
- Electrons liberated by photon interaction are stored in the depletion region up to the **full well** reservoir capacity.
- The resulting charge that accumulates in each pixel is linearly proportional to the number of incident photons.
- The stored charge is linearly proportional to the light flux incident on a sensor pixel up to the capacity of the well.

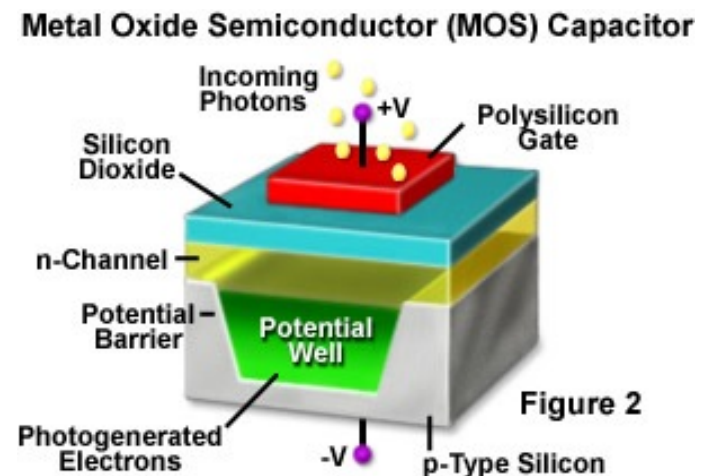

IAS : CCD and CMOS comparison

- Because of the manufacturing differences, there are several noticeable differences between CCD and CMOS sensors.
- CCD sensors create high-quality, low-noise images. CMOS sensors, traditionally, are more susceptible to noise.
- Because each pixel on a CMOS sensor has several transistors located next to it, the light sensitivity of a CMOS chip is lower.
- Many of the photons hitting the chip hit the transistors instead of the photodiode.
- CMOS sensors traditionally consume little power.
- CCDs, on the other hand, use a special process that consumes lots of power. CCDs consume as much as 100 times more power than an equivalent CMOS sensor.
- CMOS chips can be fabricated on just about any standard: cheaper.

IAS : CCD and CMOS comparison

- CCD sensors have been mass-produced for a longer period of time, so they are more mature.
- They tend to have higher quality pixels.
- Based on these differences, CCDs tend to be used in cameras that focus on high-quality images with lots of pixels and excellent light sensitivity.
- CMOS sensors usually have lower quality, lower resolution and lower sensitivity.
- However, CMOS cameras are much less expensive and have great battery life.

IAS : CCD and CMOS cameras image reconstruction

- Once color filter array has been obtained, each pixel is assigned only one color component: need of reconstruction of the RGB color.
- RGB pixel values are reconstructed using an interpolation filter applied to the color filter array.
- For each pixel and each color component, the missing components are interpolated from neighboring components of the same kind: linear, cubic, cubic spline.

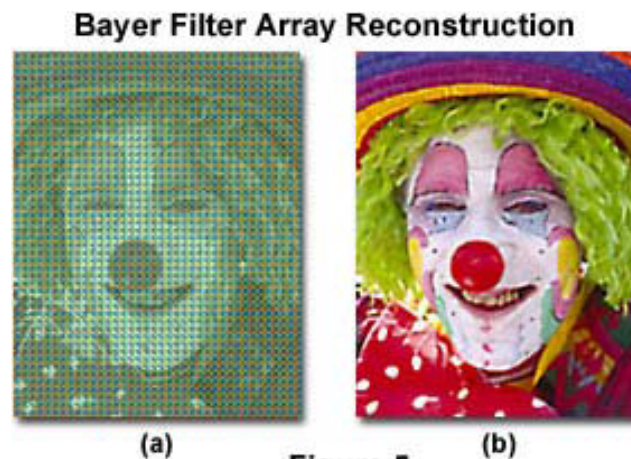

IAS : CCD and CMOS cameras image reconstruction

- In practice CMY is used rather than RGB to reduce absorption of light.
- High quality cameras: no Bayer filtering, 3 arrays of sensors, one for each component.

IAS : CCD and CMOS cameras image reconstruction

- **Pre capture algorithms:**

- **Auto-White-Balancing (AWB):**

When a scene is captured on a picture, the illuminating context is lost, color constancy does not hold anymore, and white balancing is required to compensate colors. AWB relies on the analysis of the picture in order to match the white with a reference white point. White balance adjustment attempts to reproduce colors naturally so images are not affected by surrounding light.

- **AutoExposure (AE):** determines the amount of light hitting the sensor. How light or dark the resulting photo will be

- **Auto-Focus (AF):** the Auto-Focus algorithm directly affects picture sharpness. Essentially, it consists in extracting a measure of the high frequency content of the picture and changing the focus setting until this measure reaches a maximum.

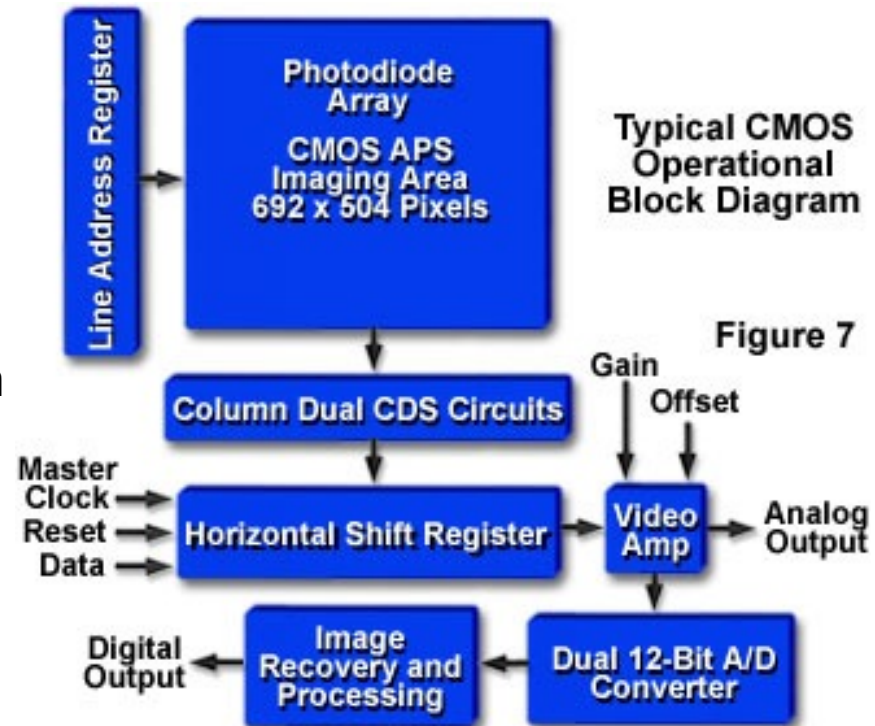

IAS : CCD and CMOS cameras image reconstruction

- **Post capture algorithms:**

additional image processing steps in the recovery engine :

- spatial distortion correction, white and black balance, smoothing,
- sharpening, color balance, gamma adjustment.

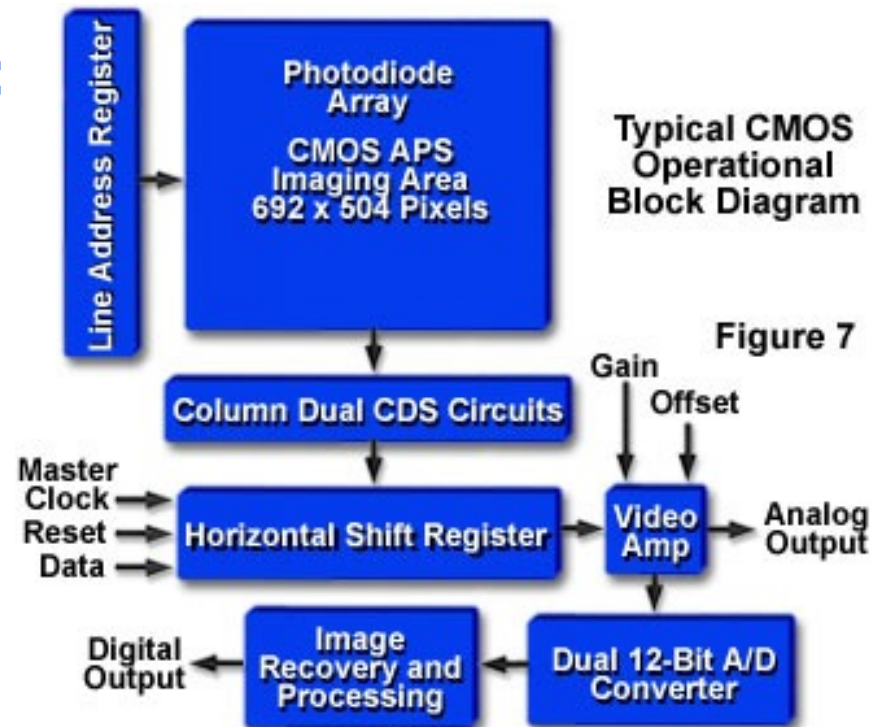

IAS : CCD and CMOS cameras

image reconstruction

- **Gamma correction:**

- In the ideal situation, the image generated by a CCD or CMOS image sensor is the result of a linear relationship between the intensity of light bathing the photodiode array and the signal gain and offset output to the display device.
- The relationship (**transfer function**) between the input illumination and the output signal is defined by the equation:

$$\text{Output Signal } \mathbf{S(o)} = \mathbf{K (E)}^\gamma$$

- where **S(o)** is the gain of the output signal, **K** is a proportionality constant, **E** is the exposure time (related to intensity), and **γ** is a measure of the device linearity (**gamma**).
- **γ** is less than 1: dark features in the image become brighter, but overall image contrast is reduced between the very bright and midtone grayscale values.
- **γ** has a value between 1 and 3, bright features become darker and overall contrast is increased

IAS : CCD and CMOS cameras image reconstruction

- **Gamma correction:**

- (a): γ is equal to 0.45
- (b): γ is equal to 1
- (c): γ is equal to 2.5

Gamma Corrections on Stained Mammalian Elastic Cartilage

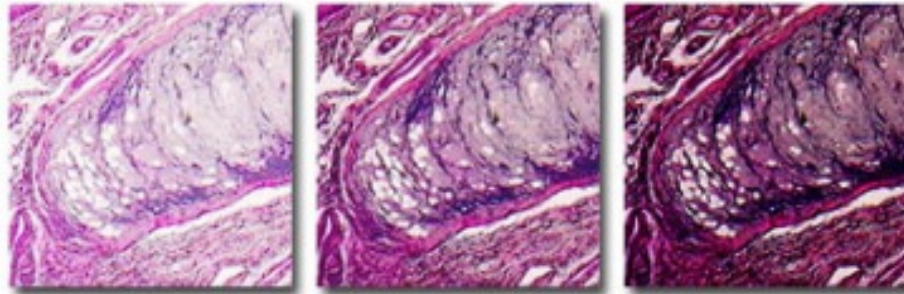

(a)

(b)

(c)

Figure 2

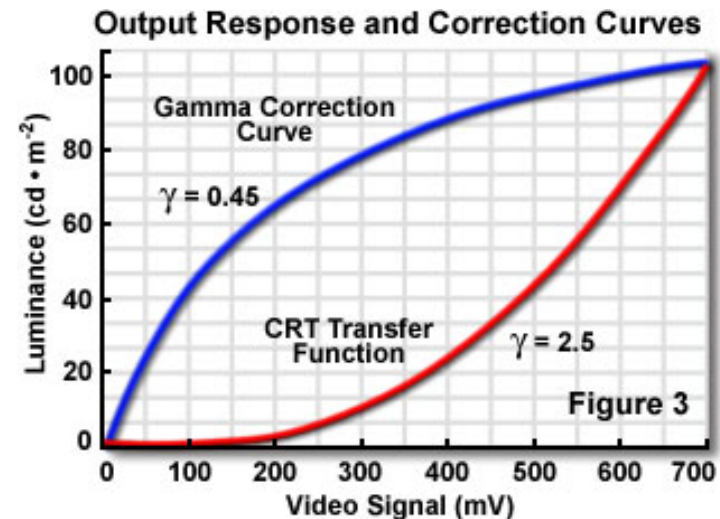

DT: Display Technology

DT: Display Technology

- **From CRT displays to flatter screens** known as Flat Panel Displays (FPD) based around two newer technologies: Liquid Crystal Display (LCD) and Plasma.
- Initially, LCD, which is not only thin but also lightweight, was seen as the only viable technology for mobile computing platforms such as the laptop and mobile phone.

DT: Display Technology

- However, the forthcoming introduction of High Definition TV (HDTV) was the driver to start the commercial redevelopment of Plasma in the 1990s, since the clarity of HDTV can not be fully appreciated on CRT TVs and, at that time, LCD could not be manufactured with a large enough screen size.
- Since then, developments in the manufacturing of LCD have allowed larger size TVs to be manufactured and this has led to increasing competition between the two FPD technologies in the TV market, particularly in the size range of 32 to 42 inches .

DT: Display Technology

Plasma (PDP)

- A Plasma display panel (PDP) is an emissive type of flat panel display (FPD).
- A plasma is an ionized gas (a gas in which a significant fraction of molecules have lost an electron).
- In a PDP, large numbers of tiny cells or pixels of around 0.5mm, containing neon or xenon gas, are sandwiched between two glass plates in a series of rows of columns which are connected to electrodes.
- The gas becomes ionized when alternating electric current is applied at the electrodes at the front and rear of the cell releasing ultraviolet (UV) photons.

DT: Display Technology Plasma (PDP)

- At the front of each cell is a group of three sub-pixels coated with red, green, and blue phosphors (also known as scintillators), which illuminate when the UV photons reach them.
- Varying the current flowing through each cell varies the levels of colour from each group of phosphors providing a large palette of colour.

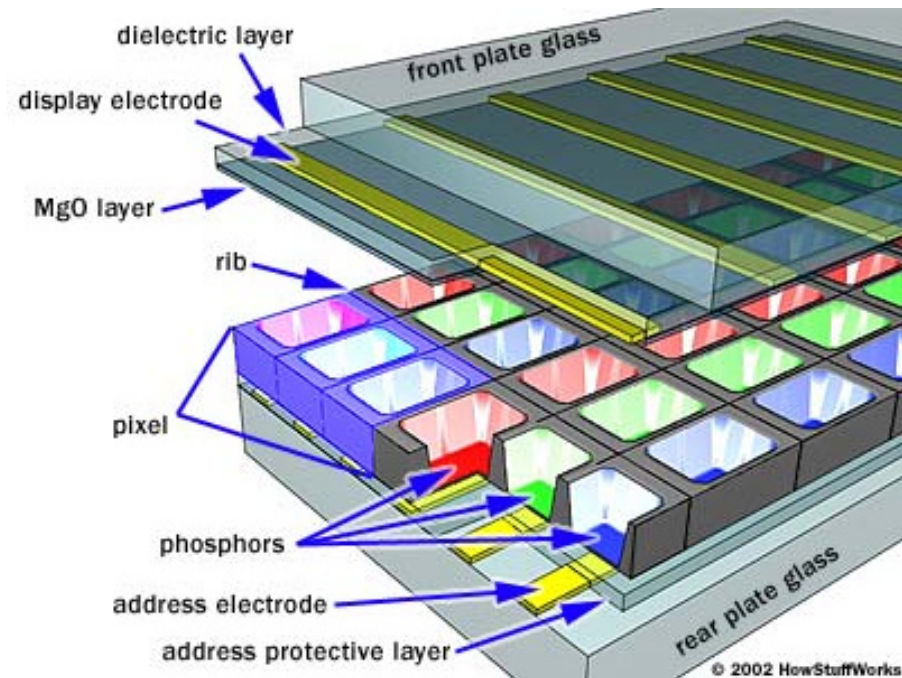

DT: Display Technology

LCD

- An LCD display is composed of a number of pixels sandwiched between two layers of polarizing light filters (one for horizontal light and one for vertical).
- Each pixel is made up of a cell of liquid crystal molecules suspended between two electrodes which act as 'gates' for light traveling between two polarizing filters.
- **Nematic phase**: matter in a **state** that has properties **between** those of conventional **liquid** and those of **solid crystal**
- In the nematic phase, liquid crystal molecules **are oriented on average along a particular direction**. By applying an **electric or magnetic field**, the **orientation** of the molecules can be **manipulated** in a predictable manner.
- Electric voltage applied to the pixel cell causes the liquid crystal to align or 'twist' itself parallel to the electric field.
- The cell is subdivided into colored sub-pixels, red, green and blue, each with a corresponding color filter.

DT: Display Technology

LCD

- Light sent through the twisted liquid crystal structure curls following the molecular arrangement. By changing the orientation of the liquid crystals, light propagating through is also changes to follow.

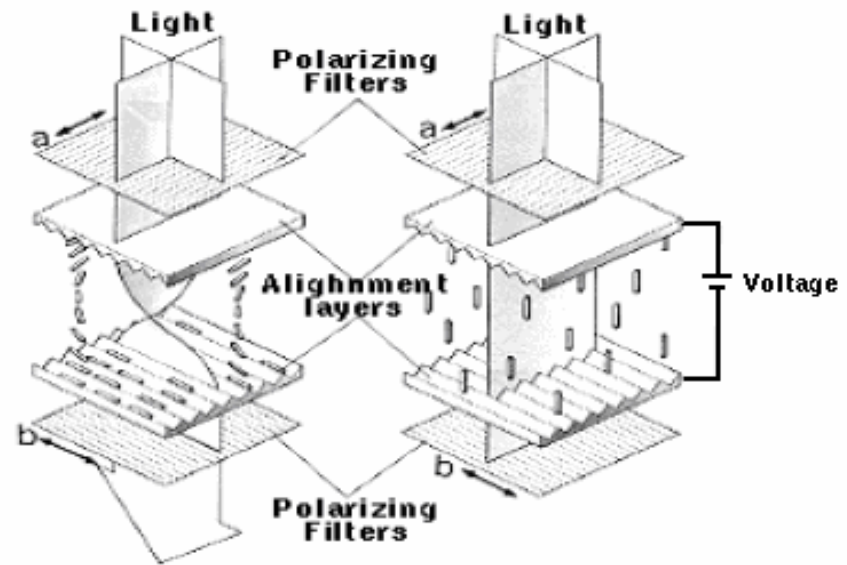
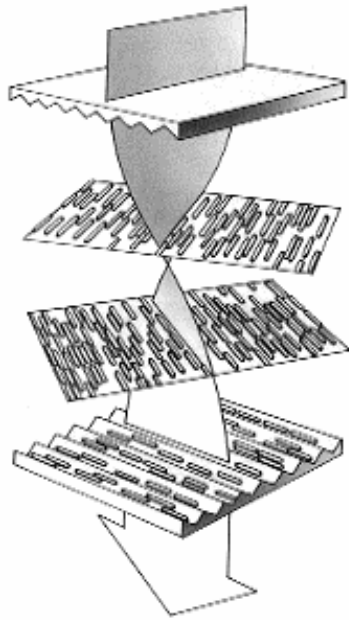

DT: Display Technology

LCD

Transmissive LCD

- With no charge, and hence no twist, incoming light passes through the horizontal filter, but cannot pass on through the vertical filter since one has polarized the light vertically and the other will do so horizontally.
- With charge, the twist in the liquid crystal alters the rotation of the light between the filters and allows some light waves to pass through.
- This light passes through the vertical polarizer, thus causing the pixel in question to appear illuminated. The amount of twist can be controlled.

DT: Display Technology

LCD

- Stylized view of transmissive LCD display

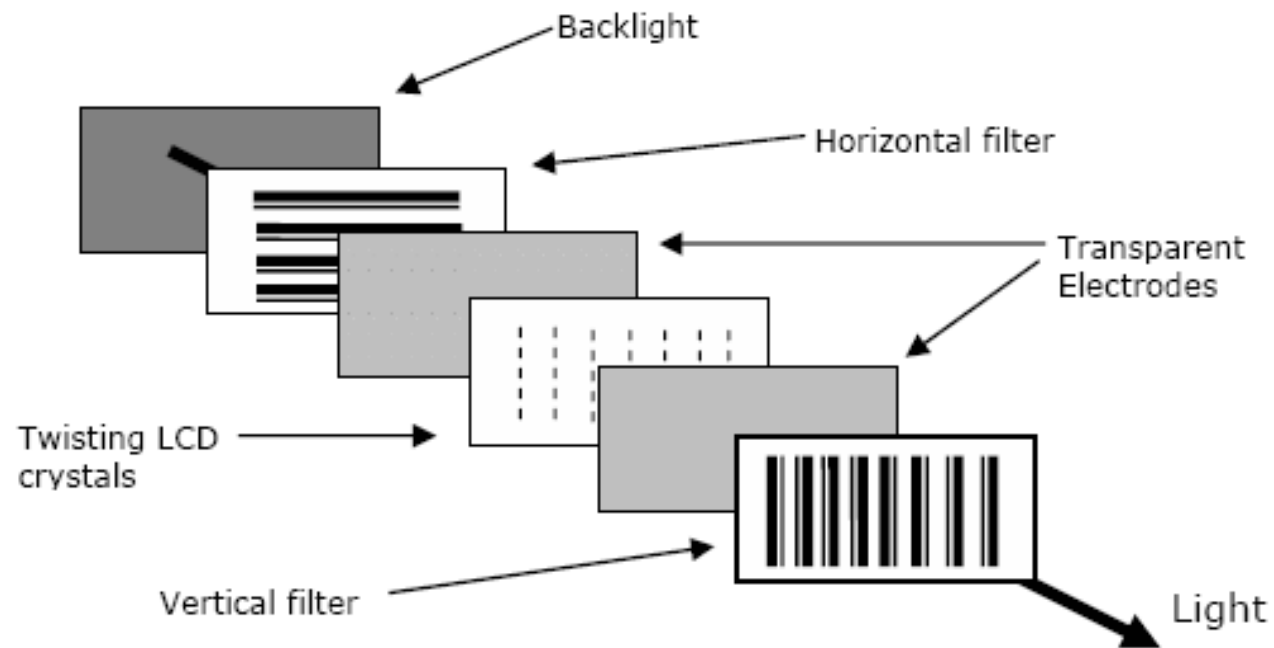

DT: Display Technology

LCD

- With no charge, and hence no twist, incoming light passes through the horizontal filter, but cannot pass on through the vertical filter

Liquid Crystal Display Structure

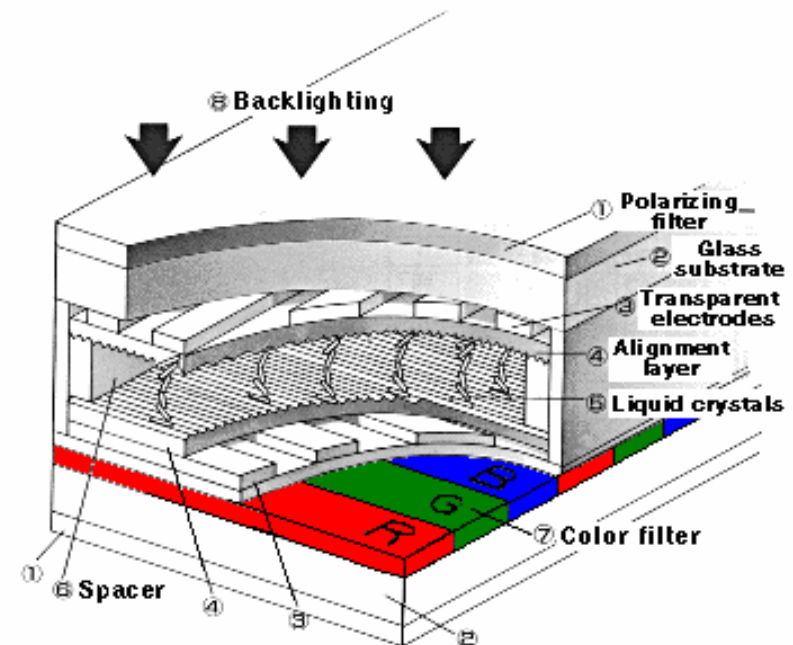
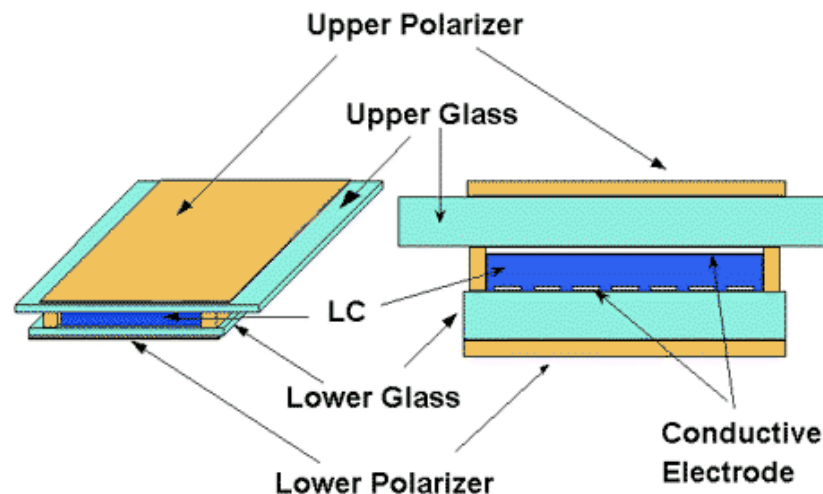

DT: Display Technology Factors

- **Brightness**: the level of light intensity perceived by the viewer.
- **Luminance**: physical quantity related to brightness, expressed in cd / m^2 . The amount of light emitted, or reflected, from a source or an object in a given direction.
 - Moonlight = $0.1 \text{ cd} / \text{m}^2$
 - Indoor light = $100 \text{ cd} / \text{m}^2$
 - Sunlight = $10000 \text{ cd} / \text{m}^2$
- **Dynamic range**: the ratio between the maximum and minimum luminances that can be generated.
- **Gamma correction**: due to limited dynamic range, same problem as camera.

DT: Display Technology Factors

- Contrast:

- $\Delta L/L = (\text{Luminance_object} - \text{Luminance_back}) / \text{Luminance_back}$
- The information that can be conveyed to a user through a display technology is fundamentally limited by the human ability to discern such contrast, and the ability to display contrast is therefore a key factor in the design of display technologies.
- The eye's ability to discern contrast is known as 'contrast sensitivity' and is a measure of how faded or 'greyed-out' an image can be before it becomes indistinguishable from a uniform background.
- Higher contrast is required to detect or 'resolve' smaller objects and this resolution limit is related to contrast and visual acuity.
- The minimum contrast sensitivity the HVS can detect is an intensity difference between two patches where the ratio of their intensities differs by at least about one percent .

DT: Display Technology Factors

- Color gamut : chromatic range
 - Color monitors emit or reflect light of varying strength for each of three primary colors – red, green and blue – and then mix them to generate a color image.
 - Color gamut is the measure of a monitor's ability to generate and display such a range of colors. The gamut possible from a particular display is dependent on the mechanism used to generate color and is bounded by the degree of saturation possible for each of the three primary colors.

DT: Display Technology Factors

- Color gamut (continued)
 - The “Commission Internationale de l'Eclairage” (CIE) developed a three dimensional color 'space' that allows any visible color to be mapped.
 - It uses three, standardized colors that are derived from red, green and blue, but which are represented by x , y , and z .
 - This color space is bounded by the purest colors i.e. those which consist solely of a dominant wavelength.
 - Any color can be located within the color space and its composition from each of the three primaries can also be determined.

DT: Display Technology Factors

- Color gamut (continued):
- Chromaticity diagram:

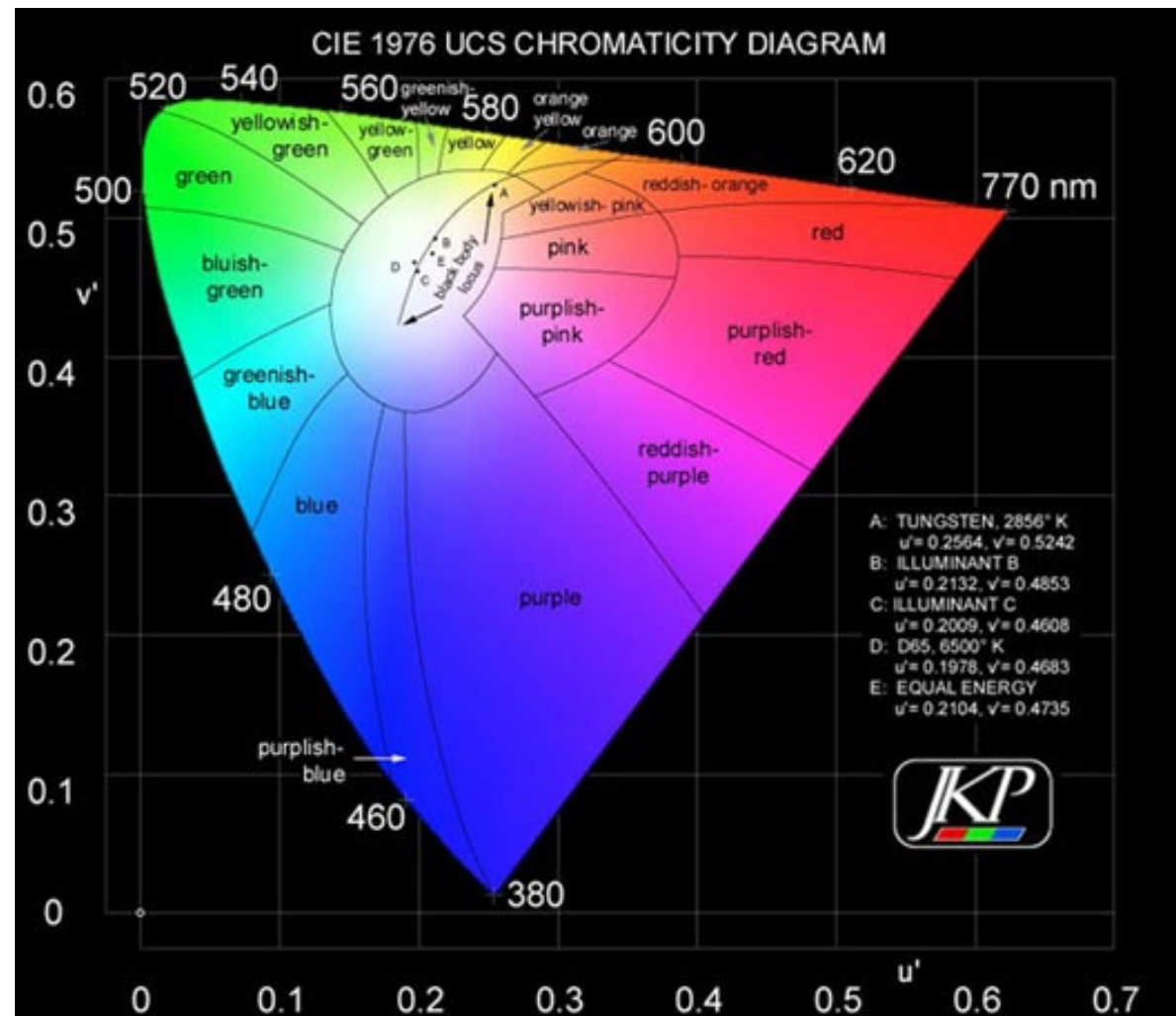

DT: Display Technology Factors

- Color gamut (continued):
 - Chromaticity coordinates for different display technologies.
 - The color gamut provided by displays is much smaller than the range the HVS can process.
 - This means that images displayed on a screen will always seem less rich than they appear in real life.

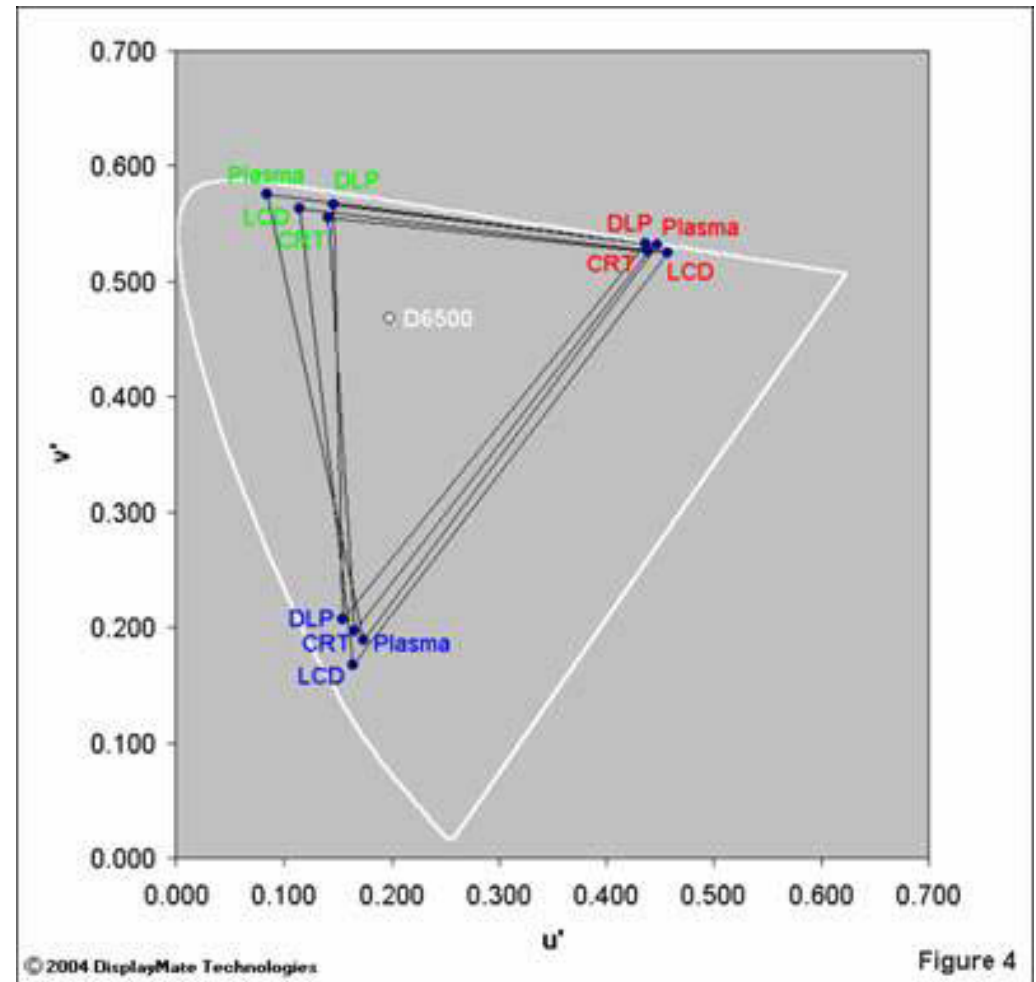

I3DST : 3D Scanning Technology

3DST: Acquiring Visually Rich 3D Models

Goal:

Build accurate digital models to clone the reality (shape + surface reflection properties)

Acquisition methodologies:

- Standard CAD modeling
- Image-based Rendering
 - *Panoramic images: 2D model!*
- Image-based Modeling
 - *“Blocky” 3D models*
- **3D scanning**



3DST: Why?

Modeling tools developed for CAD applications:

- complex -- require skilled users
- not adequate for the **accurate** reproduction of highly complex, free form surfaces (e.g. works of art):

CAD modeling → accuracy of the model often unknown (with respect to the original)

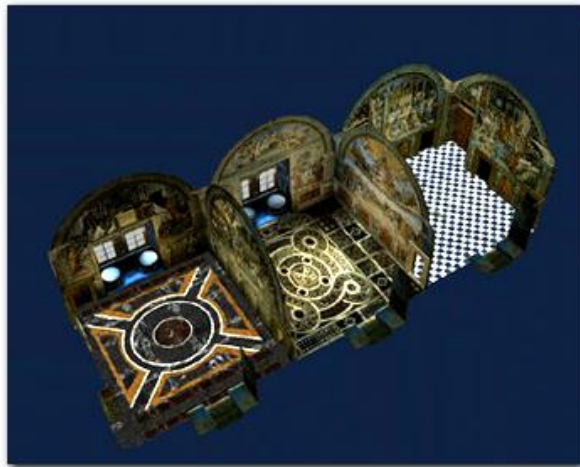

Raffaello's Apartments and S. Peter Basilica
by InfoByte - Italy

3DST: 3D Scanning

Characteristics of an *optimal* 3D scanner:

- truly 3D
- accurate
- fast
- easy to use and to move in the acquisition space
- safe, both for the user and the reconstructed object
- capable of capturing object appearance (color or radiance)
- low price

3DST: 3D Scanning - Output

- Data produced in output:

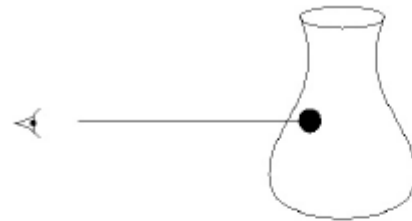

Point

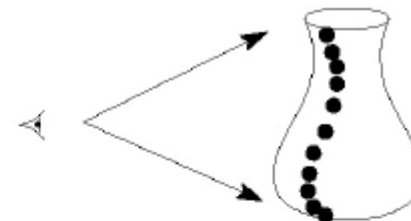

Profile

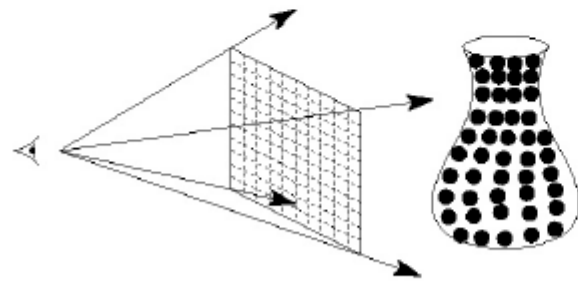

Range image

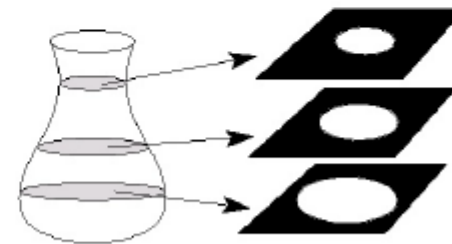

Volumetric

3DST: Contact Techniques -- Probing

- Contact probe acquisition:
 - Hand-held, manually assisted
e.g. Immersion-MicroScribe3D (low cost)
 - Robotic, industrial systems
(high cost, very high precision)

- Disadvantages:
 - **Very long** acquisition time
(manual positioning)
 - Sampling accuracy (how do we choose the points to be sampled?)
 - No data on **appearance**



3DST: 3D automatic acquisition technologies

Overview of [some] optical technologies

– Passive:

- reconstruction from silhouettes

– Active:

- triangulation-based devices
 - laser-based
 - structured light: *patterns of light projected onto objects that are viewed by cameras and interpreted by cameras (parallel lines projected into curved lines, 3D shape of the object).*
- time-of-flight devices

3DST: Active Tech. -- Optical Technologies

- Using light is much faster than using a physical probe
- Allows also scanning of soft or fragile objects which would be threatened by probing
- Three types of **optical** sensing:
 - **Point**, similar to a physical probe:
 - uses a single point of reference, repeated many times
 - slow approach, as it involves lots of physical movement by the sensor.
 - **Stripe**
 - faster than point probing, a band of many points passes over the object at once
 - it matches the twin demands for **speed** and **precision**.

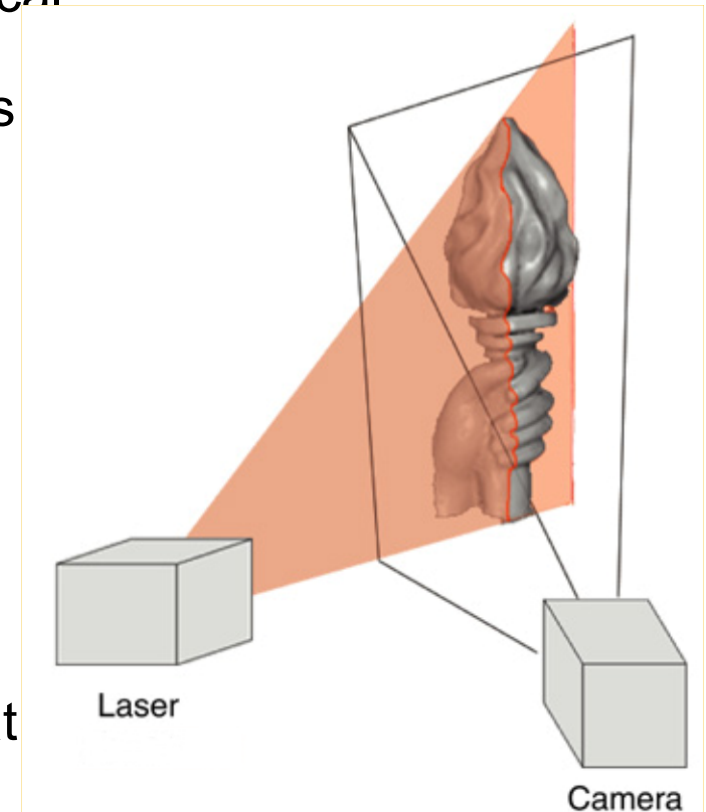

3DST: Optical -- Laser Scan

Why are lasers a good idea?

- Compact
- Low power
- Tight focus over long distances
- Single wavelength is easy to isolate in images (filter out background illumination)
- No chromatic aberration



But

- Commercial laser scanners appeared 10-15 years ago
- Product evolution is rather slow, prices did not drop down so fast.

3DST: Optical -- Laser Scan

Triangulation scanning configurations:

- A scene can be scanned by sweeping the illuminant
 - **Galvanometric mirror** (e.g. KonicaMinolta Vivid 9xx)
 - **Translation** of the entire scanning unit (Cyberware)

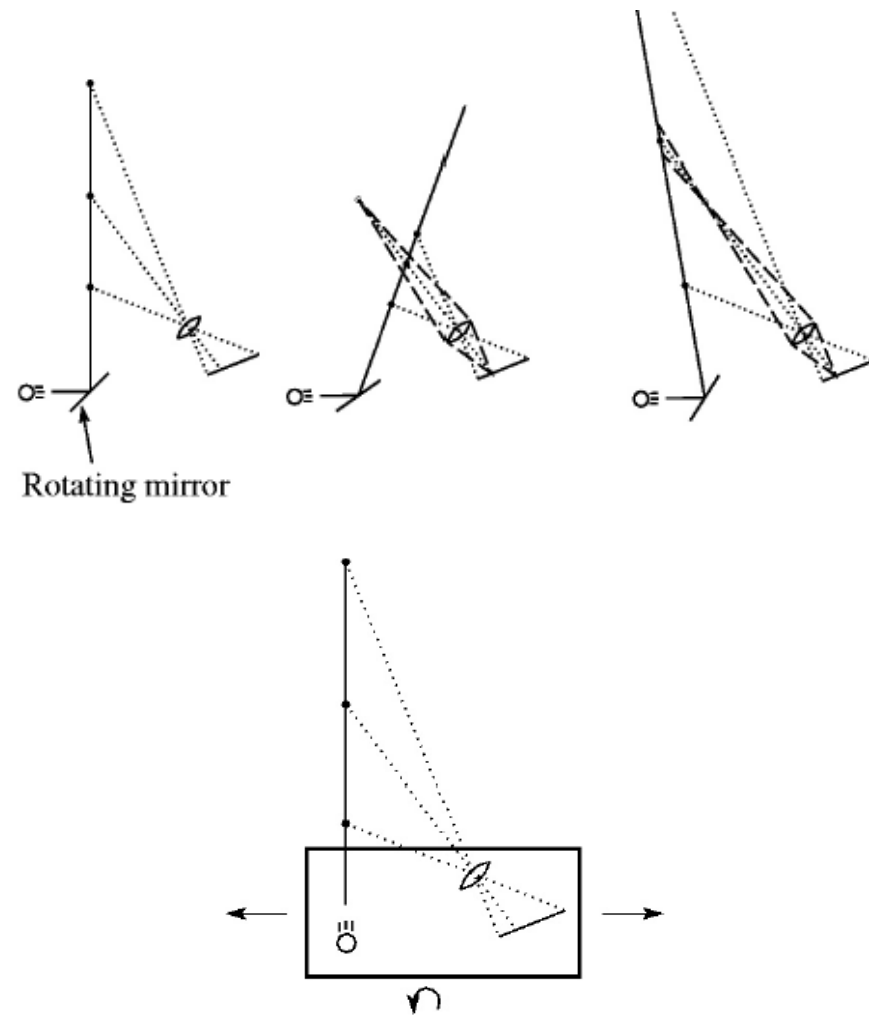

3DST: Optical Tech. – Time of Flight

- Measure the **time** a light impulse needs to travel from the emitter to the target point (and back)
 - Source: emits a **light pulse** and starts a **nanosecond watch**
 - Sensor: detects the reflected light, stops the watch (**roundtrip time**)
 - Distance = $\frac{1}{2}$ time * lightspeed [e.g. 6.67 ns \rightarrow 1 m]
- **Advantages:** no triangulation, source and receiver can be on the same axis \rightarrow smaller footprint (wide distance measures), no shadow effect:

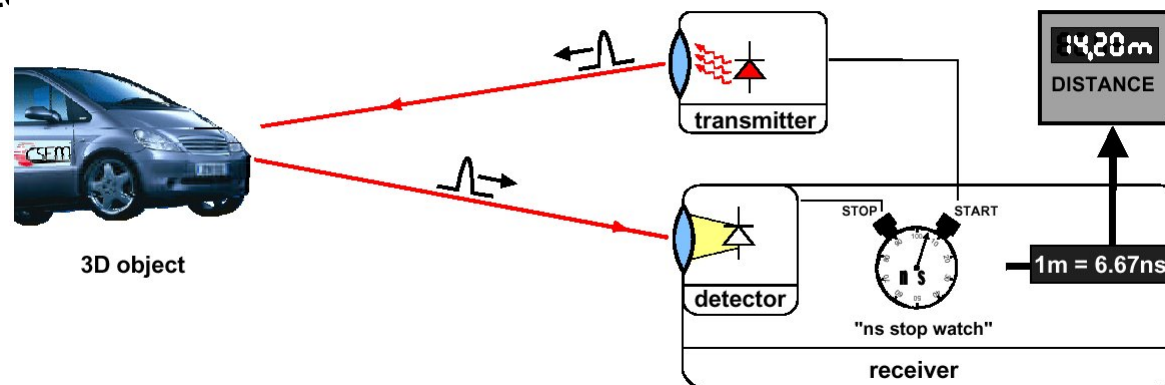

3DST: Optical– Time of Flight

- Optical signal:
 - **Pulsed light**: easier to be detected, more complex to be generated at high frequency (short pulses, fast rise and fall times)
 - **Modulated light** (sine waves, intensity): phase difference between sent and received signal → distance (modulo wavelength)
 - A combination of the previous (**pulsed sine**)
- Scanning:
 - single spot measure
 - range map, by rotating mirrors or motorized 2 DOF head

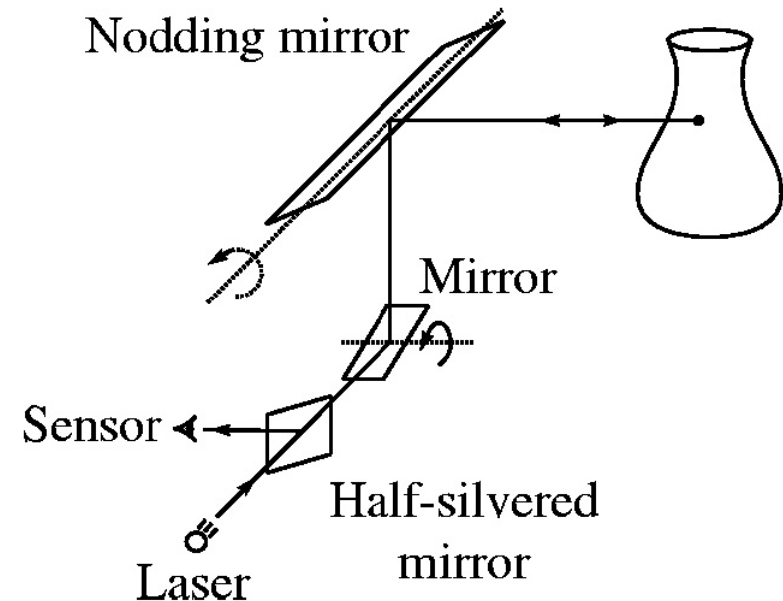

3DST: Optical Technologies

Advantages

- Non contact
- Cheap (low quality device)
- Safe (but should prevent object-scanner collision!)
- Fast

Disadvantages

- Expensive (high quality device)
- Acquire **only** the **visible surface properties** (no data on the interior, e.g. cavities)
- **Sensitivity** to surface properties:
 - transparency, shininess, rapid color variations, darkness (no reflected light), subsurface scatter, confused by inter-reflections